

Model 1290 Strain Gage Input Indicator Installation and Operation Manual



P/N 974066
02/03 Rev. G
ECO # 27622



CONTENTS

Quick Start Instructions	3
1. Indicator Description	5
2. Specifications	6
3. Installation	9
4. Setup	11
5. Operating Mode	21
6. Default Data Loading Procedure	23
7. Error Messages	25
8. Repair	27
9. Warranty	27

3. SCALING

- Insert instrument in case and tighten screw.
- Display will indicate 1290 then CONF.
- Push F key three times. Display will read F.S.U. (Full Scale Value).
- Using the Down arrow key, select the value that matches the full scale of the transducer. Enter with F key. (If your transducer is 10,000 PSI, no adjustment is necessary.)
- Remove instrument from case and close mode selection switch as shown.
- Reinsert instrument into case and tighten screw.

4. CALIBRATION AND OPERATION

- When power is applied, display will read 1290 then a Pressure reading. At this point, be sure that no pressure is applied and that the transducer is at operating temperature.
- Press the F key and the legend LO. OFF appears. Using the Up arrow key, advance the legend to LO.ON.
- Press the F key to initiate zero calibration. After approximately 5 seconds, the legend F.U.S.C. will appear and alternate with the full-scale value.
- Press the Up arrow key to advance to the legend FU ON. using the F key, initiate the full-scale calibration. After 5 seconds, the indicator will read 0 ± 10 .
- The system is now ready for use.

1. INDICATOR DESCRIPTION

The Dynisco Model 1290 Strain Gauge Input Indicator is a flexible, programmable indicator designed for 350 ohm strain gauge based sensors, such as pressure transducers and load cells. The five digit, 0.52" LED display provides a precise, readable indication of the measured value.

You can program the 1290 to display in engineering units up to a full scale value (fsv) of 99,900 with an accuracy of $\pm 0.1\%$. The span value, alarm set points and other constants are stored indefinitely in non-volatile memory. Easy-to-remember pushbutton sequences simplify transducer calibration routines.

Two independent SPST alarm relays are another available feature of the 1290. The dual high or low set points are easily programmed from the front keyboard and are displayed on the digital display. The low alarms can be set up as low-alarm-masked to inhibit alarm action during startup. Relay contacts are provided to activate an annunciator or to initiate automatic shutdown if operating conditions exceed preset limits.

A programmable voltage or current retransmission output is available as an option. You can select a voltage output of 0-10 VDC or current outputs of 4-20 mA or 0-20 mA to drive chart recorders or data acquisition equipment

The Model 1290 can also be supplied with bidirectional and half duplex RS-485 serial communications. All signals are optically isolated and the baud rate is adjustable between 150 19200 baud. The serial communications and analog retransmission output options are mutually exclusive.

Other features of the 1290 are:

- A peak reading display (high and low) selected from the front panel
- A digital filter to reduce the effects of input variations on the display, analog output and alarms
- Input interruption sensing to detect when a transducer or any one of its leads has been disconnected
- A program lockout feature that disables the front keyboard to prevent un authorized or accidental changes
- An input signal that can be configured for either resetting the alarms or triggering hold-on-value
- A digital display that provides operator prompts with messages to show current status or errors
- A compact, 48mm by 96mm (1.89in. x 3.78 in.), 1/8 DIN enclosure that projects only 144mm (5.67 in.) behind the panel

2. SPECIFICATIONS

2.1 GENERAL

Case	PC/ABS, Black Self-extinguishing, level V-0, per UL 94
Dimensions	48 mm high x 96 mm wide x 144 mm deep (1.89 in. high x 3.78 in. wide x 5.67 in. deep) 1/8 DIN per DIN 43700
Installation	Panel mounted, secured by mounting frame
Cut-out	45 mm high x 92 mm wide, +0.8 mm/-0 mm (1.77 in. high x 3.62 in. wide, +0.03 in./-0 in.)
Front panel	IP 65 protection per IEC 569/CEI 70-1
Rear terminal block	22 screw terminals with safety cover
Display	5 red LED digits, 13.2 mm high 7 segments plus decimal point
Indicators	2 red LEDs for alarm annunciator function 1 red LED for local/remote control
Keyboard	Four pushbuttons
Sampling time	100 ms typical
Display update time	400 ms
Common mode rejection ratio	120 dB @ 50/60 Hz
Accuracy	$\pm 0.1\%$ fsv ± 1 digit @ 25°C
Temperature drift	Less than 200ppm/°C of fsv
Insulation resistance	Greater than 100 Mohm, per IEC 348
Dielectric strength	1500 V rms, per IEC 348
Power supply	Switching 85/264 VAC, 50/60 Hz (24 VDC $\pm 10\%$ factory order option)

Power consumption	100 mA @ 110 VAC maximum
Protection	Internal thermistor
Normal mode	60 dB @ 50/60 Hz
Weight	600g
Operating temperature	0 to 50°C
Storage temperature	-20 to +70°C
Humidity	85% relative humidity, non-condensing

2.2 STRAIN GAUGE INPUT

Input	350 ohm bridge
Bridge excitation	10 V +7%
Bridge sensitivity	2 to 4 mV/V
Input signal	-25% + 125% of full scale (approx -10 + 50 mV)
Calibration	With or without shunt resistor
Shunt value	From 40.0% to 100.0%
Zero balance	± 25% of fsv
Tare	± 25% of fsv
Readout	Keyboard programmable from 10 to 99900
Input resolution	Adjustable by 1 up to 2010 Adjustable by 10 from 2010 to 20100 Adjustable by 100 from 20100 to 99900 Decimal point may be set in any position
Open input detection	On any one of the 4 transducer leads, selectable up or down scale fault mode.

2.3 SPECIAL FEATURES

Display filter	First order digital filter on displayed value, with configurable time constant of 0.4, 1, 2, 3, 4 or 5 seconds
Peak detection	Automatic detection of maximum and minimum measured value
Input logic	Driven by dry contacts for manual alarm reset or for hold-on value
Watch dog	Hardware and software for automatic restart
Protection	Internal jumper for calibration and configuration Parameter protection Keyboard lockout

2.4 ALARMS

Quantity	Two independent alarms
Threshold	0% to 100% of readout span Resolution and decimal point position as selected per readout value
Hysteresis	Programmable, 0.1% to 9.9% of readout span
Type of alarms	High or low thresholds Direct or reverse (failsafe) action Automatic or manual reset Optional low alarm startup masking
Alarm output	Two contacts, SPST, NO or NC, jumper selectable
Update time	100 ms
Contact rating	0.6A at 110 Vac resistive load; 0.5A at 220 Vac resistive load; 0.3A at 110 Vdc inductive load
Filter	Optional digital filter with the same time constant chosen for display filter

2.5 SERIAL COMMUNICATION INTERFACE (OPTION)

Type	RS-485, opto-isolated from instrument input and output
Protocol	Polling/Selecting, modbus, jbus

Baud rate	From 150 to 19200 baud
Format	7 bits + parity 8 bits + parity 8 bits without parity
Parity	Even/Odd
Stop bit	One

2.6 ANALOG RETRANSMISSION (OPTION)

Output types	0-20 mA, 4-20 mA, maximum load, 500 ohms 0-10 V, minimum load 5000 ohms Keyboard and jumper selectable Opto-isolated
Scaling	From 0 to 99900 Resolution and decimal point position are as selected per readout value
Output resolution	Better than 0.05% of output span (scaling can worsen output resolution)
Filter	It is possible to enable a digital filter on the output with the same time constant selected for the display filter
Accuracy	0.2% of output span
Temperature drift	Less than 100ppm/°C (plus input drift)
Output noise	Less than 0.1% fsv RMS
Update time	100 ms

NOTE: The analog retransmission and serial communication interfaces are mutually exclusive.

3. INSTALLATION

3.1 UNPACKING

Inspect the package for shipping damage. If you notice any damage, notify the freight carrier immediately.

3.2 MOUNTING

Fig. 1 Panel Cutout

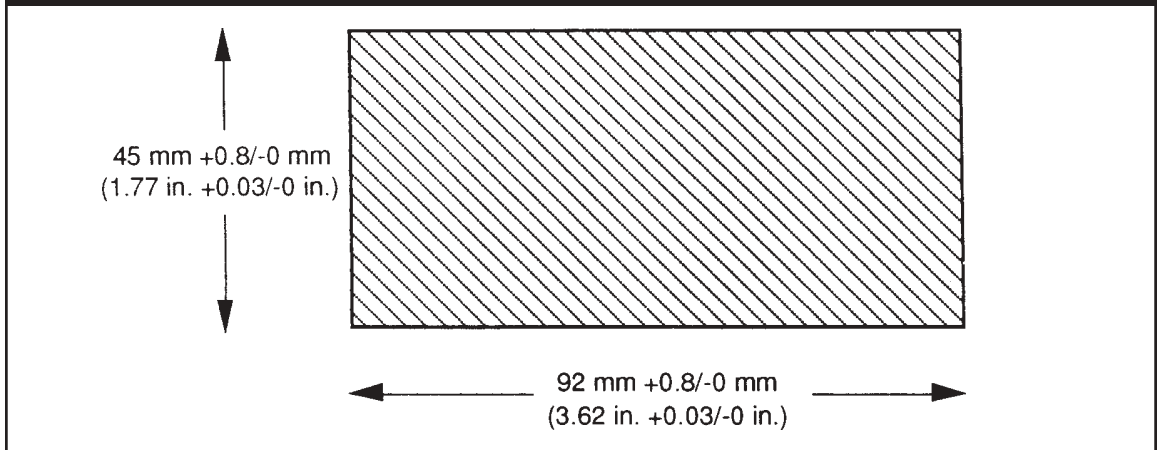

- Make the instrument panel cut-out with the specified cut-out dimensions.
- Undo the screw (2).
- Remove the unit from the instrument case (3).
- Slide the gasket onto the instrument case (3).
- Slide the the instrument case (3) through the cut-out.
- Slide the mounting frame (4) from the rear over the instrument case (3) so that the snap-in elements of the mounting frame (4) engage in the recesses at the side.
- Use a screwdriver to snug the mounting frame (4) and the instrument case (3).
- Slide the instrument from the front into the instrument case (3).
- Secure the instrument in the case with the screw (2).

Fig. 2 Side View, Mounting

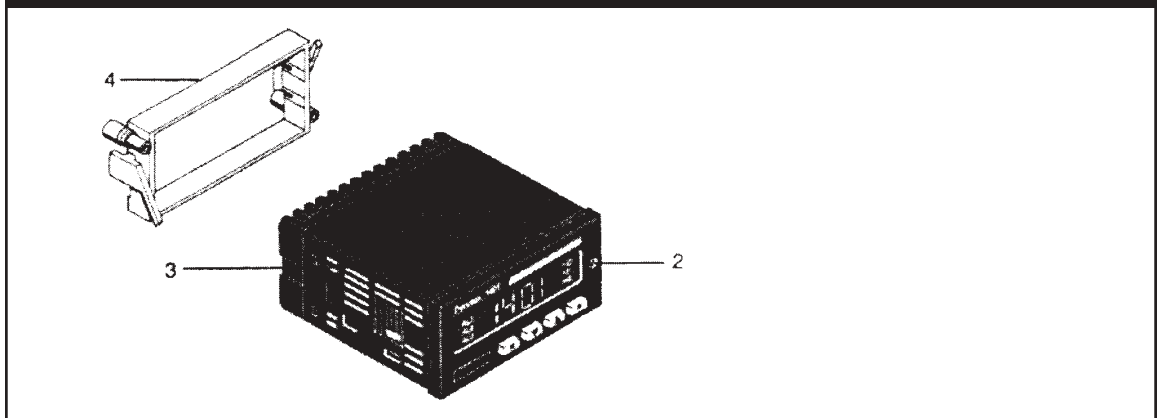

4. SETUP

4.1 FRONT PANEL

The front of the Model 1290 is shown in Figure 3. Key items on the front panel are:

- A five digit LED display
- LED indicators AL1 (Alarm 1) and AL2 (Alarm 2)
- LED indicator RS (Remote Status)
- Four pushbuttons protected by silicone rubber, labeled **R**, **▼**, **▲**, **F**. The pushbutton functions are listed in the table below.

Fig. 3 Front Panel

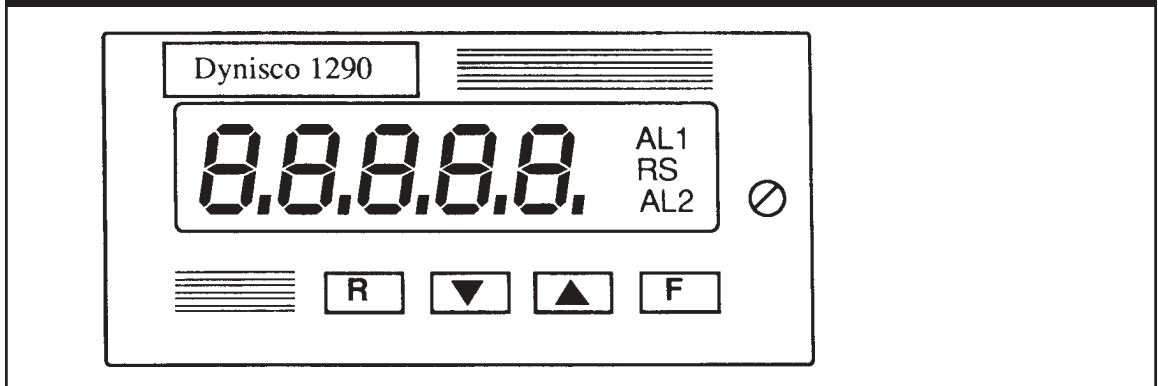

4.2 PUSHBUTTON FUNCTIONS

Button Sequence	Resulting Operation
▼	Used to step between choices or to decrement a parameter value
▲	Used to step between choices, increment a parameter value or to display peak high or peak low
F	Used to store currently displayed parameter value, as modified, and to display the next parameter
R	Used to scroll back to the previous parameter without storing the modified parameter value
R + ▼ or R + ▲	Alarm manual reset (either button sequence will reset both alarms)
R + F	Reset peak high and peak low values
▼ + ▲	Initiate default data loading procedure
▼ + R + F	Used to lock or unlock keyboard for transducer calibration and parameter modification

To perform operations requiring two or more pushbuttons, press and hold the first pushbutton then press and hold the second pushbutton, and then press the third pushbutton, if required.

NOTE: You must follow the pushbutton sequences exactly as described.

4.3 REAR TERMINAL CONNECTIONS

The electrical connections for the Model 1290 are shown in the table below. The layout of the terminals, as seen from the rear, is shown in Figure 4.

Terminal	Connection	Dynisco Wire	Terminal	Connection
1	Signal +	Red	12	Alarm 2
	(no terminal)		13	Alarm 2C
3	Signal —	Black	14	Alarm 1
4	+ Excitation	White	15	Alarm 1C
5	— Excitation/ CAL1	Green + Blue	16	N/C
6	CAL 2	Orange	17	N/C
7	Logic Input		18	Remote Enable
8	Logic Input		19	Remote Enable
9	Line (Hot side) VAC, or +24 VDC		20	A/A'
10	Line (Neutral), or 0 VDC		21 Output	V/mA+ B/B'
11	Ground		22 Output	V/mA- C/C'

NOTE: Do not connect any wires to terminals 16 and 17.

Fig. 4 Rear Terminal Locations

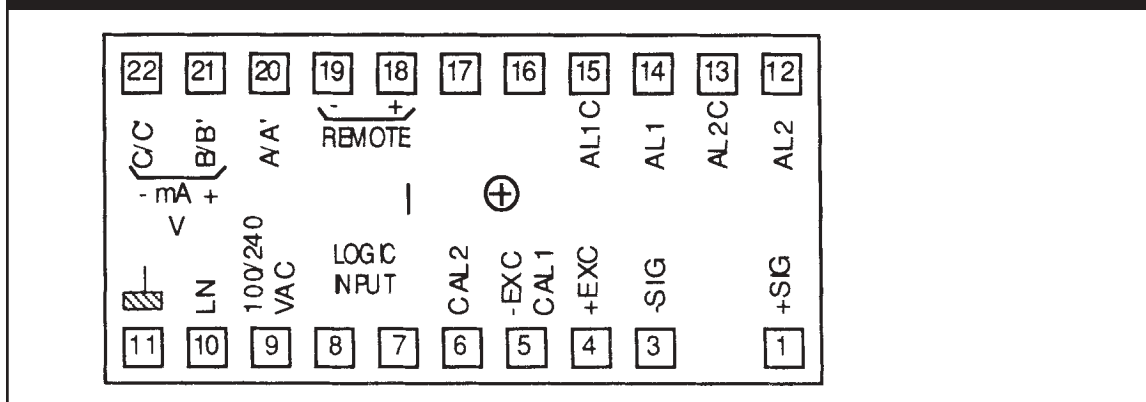

4.4 INPUT WIRING

Connect the pressure transducer per the instructions detailed below. Do not run input wires in the

same bundle with power cables; instead, shielded cable should be used and grounded at the transducer end only (Dynisco's cable assembly provides this grounding).

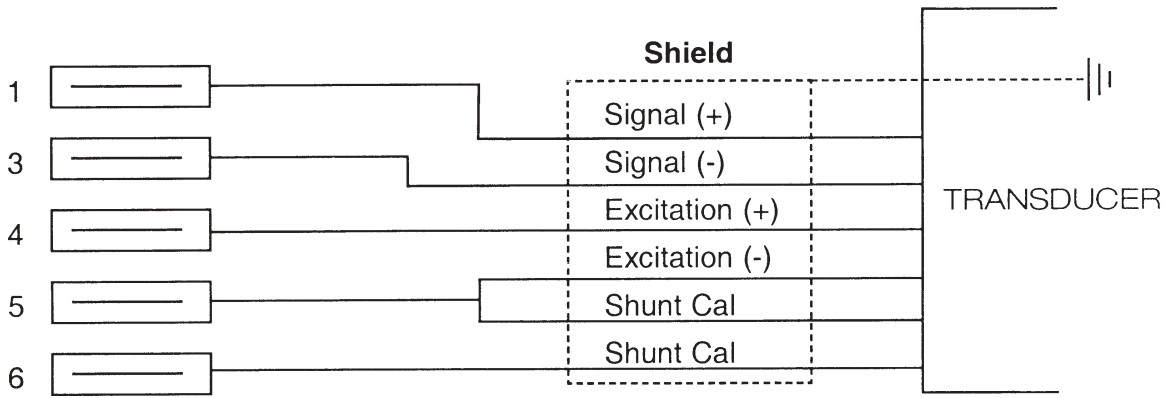

Dynisco Standard Wire Code		Transducer Pin-Out	
Lead	Color	PT420 Series	PT460 Series
Excitation +	White	A	C
Signal +	Red	B	A
Excitation -	Green	C	D
Signal -	Black	D	B
Calibration	Blue	E	E
Calibration	Orange	F	F
		G (unused)	
		H (unused)	

4.5 INTERNAL SETTINGS

The indicator consists of an upper and a lower printed circuit board and a front panel. These are connected by ribbon cables which are soldered in place.

CAUTION: Be careful not to twist the ribbon cables during assembly and disassembly.

4.5.1 DISASSEMBLY

1. With a small slotted screwdriver, loosen the captive screw on the right side of the front panel.
2. Slide out the front panel and printed circuit board assembly, and place it on a flat, anti-static work surface. Notice that the circuit boards are held in place by four plastic clips. See Figure 5.

Fig. 5 Front Panel and Circuit Board Assembly

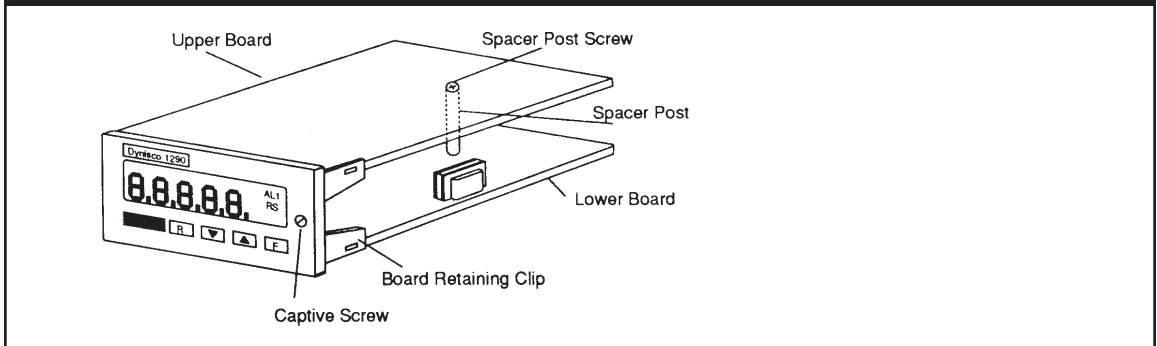

4.5.2 OUTPUT JUMPER SETTINGS

Output options are selected by the placement of jumpers on the upper circuit board. The choices available are:

- Voltage or current loop output for analog retransmission. Jumper setups are shown in Figure 6. The default selection is a 4-20 mA current output, with alarm outputs normally closed.
- The alarm jumpers (normally open or normally closed) are shown in Figure 6 and described in the table on the next page. Each alarm is configured independently.

CAUTION: Wear an anti-static wristband and work on an anti-static surface when setting jumpers.

Fig. 6 Upper Circuit Board and Jumper Settings

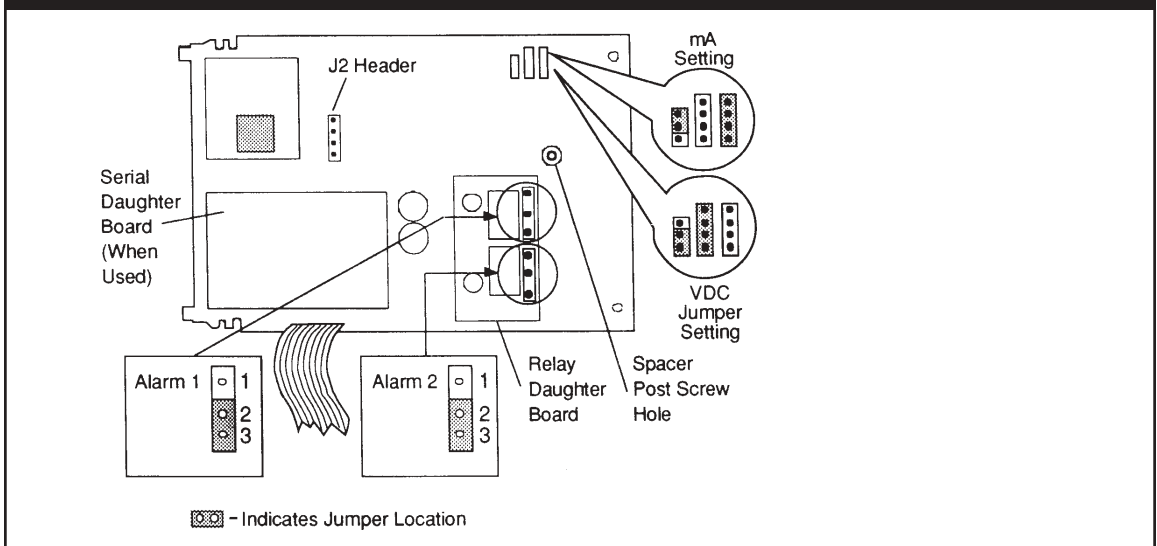

The table below describes the alarm contact status based on the alarm jumper settings as selected from Figure 6 and the state of the Alarm Action settings as described in G1 and H on page 18.

Alarm Action	Alarm Jumper	Contact Status
Reverse (fail safe)	1-2 (NO)	Contacts open in alarm or power loss
Direct	1-2 (NO)	Contacts closed in alarm
Reverse (fail safe)	2-3 (NC)	Contacts closed in alarm or power loss
Direct	2-3 (NC)	Contacts open in alarm

4.5.3 MODE SELECTION

The Mode Selection Switch determines whether the indicator will be in configuration/calibration mode or the normal operating mode.

NOTE: The Configuration/Calibration Mode is only used when the indicator is first installed, or when reconfiguration of the indicator is required. At all other times, the operating mode is used.

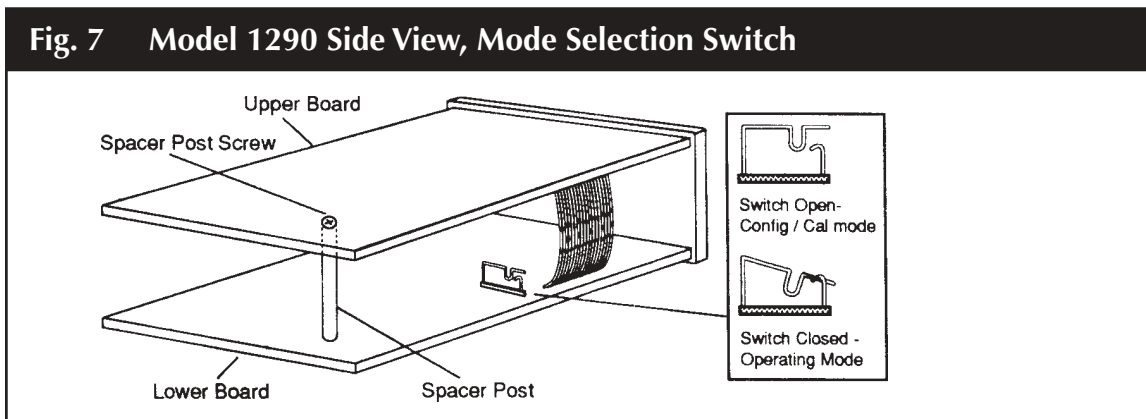

To access the Mode Selection Switch slide out the front panel and printed circuit board assembly, as instructed by steps 1 and 2 of Disassembly on page 13. Then, refer to Figure 7 to locate the switch and change the setting. Once the switch is set, refer to the following Reassembly procedure.

4.5.4 REASSEMBLY

To reassemble the Model 1290, follow the steps below.

1. Slide the front panel and printed circuit board assembly into the instrument case and press it in so that the printed circuit board contacts mate with the terminal block in the back of the case. Tighten the front panel captive screw.
2. Perform configuration as outlined on the following page to ensure proper indicator setup and operation.

4.6 CONFIGURATION/CALIBRATION MODE

The configuration/calibration mode is enabled by opening the Mode Selection Switch on the left side of the lower board (see Figure 7). A list of all configurable parameters starts below.

When the unit is turned on in configuration/calibration mode, the display will show **1290** and then **COnF**.

Press **F** to initiate the configuration procedure, starting at the first parameter.

Press **R** to initiate the configuration procedure, starting at the last parameter.

Press **▲** to toggle the display from **COnF** to **CAL**, initiating output calibration mode, if required.

Pressing **▼** will display the software version number.

For each parameter you will either select one of several choices or enter a numerical value.

Press **▲** to modify or change the parameter or increase the number displayed.

Press **▼** to modify or change the parameter or decrease the number displayed.

Press **F** to save your changes and step to the next parameter.

Press **R** to step to the previous parameter without saving your changes.

For many parameter settings, the display initially alternates between a code and a numerical value. Once you start to modify the value, however, only the numerical value will be shown.

When entering a numerical value, **▲** and **▼** are used to increase or decrease the number being entered. The change in value for each step is either 1, 10, or 100, depending on the size of the number. The increment is 1 for values up to 2010, 10 from 2010 to 20100, 100 from 20100 to 99900.

4.7 CONFIGURABLE PARAMETERS

The following is the complete sequence of configurable parameters. Default values are given on page 24.

A. LINE FREQUENCY

The display shows **L.F.** (Line Frequency) followed by:

60 for 60 Hz, or

50 for 50 Hz

B. DECIMAL POINT POSITION

The display shows:

---- for no digits after decimal point

----. for one digit after decimal point

---. for two digits after decimal point

--. for three digits after decimal point

-. for four digits after decimal point

B1. FULL SCALE READOUT

The display alternates between **F.S.U.** (Full Scale Value) and a numerical value from 10 to 99900. Only the numerical value will be shown during modification., This value **MUST** be set equal to the sensor full range, e.g. 10,000 PSI.

C. DISPLAY FILTER TIME CONSTANT

The display shows **F.T.C.** (Filter Time Constant) followed by:

- .4** for 400 millisecond filter time constant
- 1** for 1 second filter time constant
- 2** for 2 second filter time constant
- 3** for 3 second filter time constant
- 4** for 4 second filter time constant
- 5** for 5 second filter time constant

D. INPUT INTERRUPT

The display shows **I.F.S.** (Input Fail Safe) followed by:

- Hi** for up scale fail mode, or
- Lo** for down scale fail mode.

E. SHUNT CALIBRATION

The display shows **S.C.** (Shunt Calibration) followed by:

- On** for shunt calibration enabled, or
- OFF** for shunt calibration disabled.

NOTE: Set Shunt Calibrations to **On** when using Dynisco transducers.

E1. SHUNT CALIBRATION VALUE

This step is skipped if the shunt calibration is **OFF**.

The display alternately shows **Shunt** and a numerical value from 40.0 to 100.0, but only the numerical value will be shown during modification. This value corresponds to the percentage of the Full Scale Value.

NOTE: When using Dynisco transducers, the Shunt Calibration value should be set to 80.0

F. EXTERNAL CONTACT function

The display shows **E.C.** (External Contact) followed by:

- nr** to enable external contact for manual alarm reset, via rear terminals 7 and 8, or
- Ho** to enable external contact for hold-on-value sampling.

F1. CONTACT STATUS

The display shows **C.S.** (Contact Status) followed by:

- CL** if function selected above is performed with contact closed, or
- OP** if function selected above is performed with contact open.

G. ALARM 1 OPERATIVE MODE

The display shows **A1** (Alarm 1) followed by:

- HA** High alarm with automatic reset
- HL** High alarm with manual reset (High Latched Alarm)
- LA** Low alarm with automatic reset
- LL** Low alarm with manual reset (Low Latched Alarm)
- OFF** for no Alarm 1

G1. ALARM 1 ACTION

This step is skipped if Alarm 1 is **OFF**.

The display shows **A1** (Alarm 1) followed by:

- rEU** for relay energized if no alarm condition (reverse action/fail safe), or
- dir** for relay energized if alarm condition (direct action).

G2. ALARM 1 MASKING OPTION

This step is skipped if Alarm 1 is **OFF** or **HIGH**.

The display shows **A1** (Alarm 1) followed by:

- dis** for masking option disabled, or
- Enb** for masking option enabled.

This function masks low alarm conditions during startup until the measured value first becomes greater than the alarm threshold plus hysteresis. The alarm must have been programmed as a low alarm.

G3. ALARM 1 FILTER

This step is skipped if Alarm 1 is **OFF**.

The display shows **F1** (Filter) followed by:

- OFF** for no filter on alarm threshold, or
- xxx** for filter with the time constant chosen in step C above.

G4. ALARM 1 HYSTERESIS

This step is skipped if Alarm 1 is **OFF**.

The display shows **H1** (Hysteresis 1) followed by a value from 0.1 to 9.9.

This value corresponds to the percentage of the Full Scale Value.

H. ALARM 2

Follow the same procedure as in steps F-F4 above.

I. SERIAL COMMUNICATIONS PROTOCOL

NOTE: This step will default to:

- OFF** if unit does not have the Serial Communications Interface option.
- ErO** if unit has the Serial Communications Interface option.

The device will support the following protocols:

- ErO** for polling/selecting protocol
- nbUS** for Modbus protocol

JbUS for Jbus protocol
OFF to disable comms

NOTE: This indicator skips steps I1 and I2 if serial communication is **not** implemented (set to ***OFF***).

I1. SERIAL COMMUNICATION DEVICE ADDRESS

The display shows ***Adr*** (address) followed by a number ranging from:

- 1-95 for polling/selecting protocol (1-31 being valid addresses)
- 1-255 for modbus/jbus protocol (up to 128 devices per multidrop link)

I2. SERIAL COMMUNICATION BAUD RATE

The display shows ***bd*** (baud rate) followed by:

- 150*** for 150 baud
- 300*** for 300 baud
- 600*** for 600 baud
- 1.20*** for 1200 baud
- 2.40*** for 2400 baud
- 4.80*** for 4800 baud
- 9.60*** for 9600 baud
- 19.2*** for 19200 baud

I3. SERIAL COMMUNICATION BYTE FORMAT

The display shows ***bF*** (byte format) followed by:

- 7E*** for 7 bits with even parity
- 7O*** for 7 bits with odd parity
- 8E*** for 8 bits with even parity
- 8O*** for 8 bits with odd parity
- 8*** for bits with no parity

NOTE: The indicator skips steps L to L3 if analog retransmission is implemented.

L. ANALOG RETRANSMISSION (Option)

The display shows ***AO*** (Analog Output) followed by:

- 0.20*** for 0-20mA
- 4.20*** for 4-20mA
- 0.10*** for 0-10 V
- OFF*** for retransmission disabled

L1. ANALOG RETRANSMISSION SCALING: LOW SCALE VALUE

The display alternately shows ***Ar. L.S.U.*** (Analog Retransmission Low Scale Value) and a numerical value. This parameter establishes the lower limit for the analog output; only the numerical value is shown during modification. Resolution and decimal point position are as selected for the readout value.

L2. ANALOG RETRANSMISSION SCALING: FULL SCALE VALUE

The display alternately shows **Ar. F.S.U.** (Analog Retransmission Full Scale Value) and a numerical value. This parameter establishes the upper limit for the analog output; only the numerical value is shown during modification. Resolution and decimal point position are as selected for the readout value.

L3. ANALOG RETRANSMISSION FILTER

The display shows **rF** followed by:

- OFF** for no filter on retransmitted value, or
- xxx** for filter having the time constant chosen in step C.

Press **F** to lock in the parameter.

At this point the configuration procedure is complete and the display will return to showing **CO_nF**.

If necessary, you may now select the analog output calibration procedure by pressing **▲**. Refer to Analog Output Calibration, below.

When configuration/calibration is complete, remove the unit again, place the Mode Selection switch in the "normal" (closed) position, and replace the unit. See Mode Selection, page 15.

Proceed to Operating Mode, page 21.

4.8 ANALOG OUTPUT CALIBRATION

Press **▲** to toggle the display from **CO_nF** to **CAL**, initiating output calibration mode.

Press **▼** to display the software version number.

Press **F** to initiate the calibration procedure, starting at the first parameter.

Press **R** to initiate the calibration procedure, starting at the last parameter.

Perform the calibration procedure in accordance with the jumper settings to select:

- Current Output, or
- Voltage output.

The jumper locations for these output selections are shown in Figure 6. When the display shows CAL, you can also load the default parameters, shown on page 24.

To calibrate the analog retransmission output, connect a multimeter, set to the proper measurement range, to terminals 21 and 22. Press the **F** key to reach desired parameter then make output adjustments by pressing **▲** or **▼** until the signal output measured by the multimeter reaches the proper value. The display only shows the number of counts for the digital to analog converter.

- C6 - Retransmission current output minimum value - adjust to 50.0 mμ
- C7 - Retransmission current output maximum value - adjust to 20.0 MA
- C8 - Retransmission voltage output minimum value - adjust to 0.00 VDC
- C9 - Retransmission voltage output maximum value - adjust to 10.00 VDC

After the last step, the calibration is complete. The display shows the measured input variable in bits (approximately 1.6 microvolt/bit).

NOTE: The above procedure only applies to indicators ordered with the output option. Units are precalibrated from the factory.

5. OPERATING MODE

In this mode the Model 1290 monitors the input signal, displays the measured value, and performs alarm functions. You can display high and low peak values, lock and unlock the keyboard, reset alarms, and perform transducer input calibration and alarm threshold settings. It is also possible to load default parameters.

Parameter values listed below can always be viewed, but they can only be modified if the indicator keyboard is unlocked. If anyone attempts to modify parameters when the indicator is locked, the display will show *inh*.

5.1 KEYBOARD LOCK/UNLOCK

When the measured value is displayed (normal operating mode), you can lock or unlock the keyboard by holding down the buttons in the following order; ▼ + **R** + **F**. The display will then show the new desired mode: **Loc** or **UnLoc**.

5.2 TRANSDUCER INPUT CALIBRATION

You can modify the operating parameters and load default data only when the instrument is unlocked and in local mode. Default values are shown on page 24.

NOTE:

1. Transducer/ Indicator calibration should be performed with the transducer at operating temperature, and with no pressure applied.
2. The Zero and Full scale calibrations should be done concurrently.

1. ZERO TRANSDUCER CALIBRATION

Press **F** to enter the calibration mode.

The display will show **LO.OFF**.

Press the ▲ key once.

The display will show **LO.On**.

Press the **F** key to perform the zero calibration.

The display will blank except for 5 decimal points.

After a brief "time out" the unit will enter full scale calibration.

NOTE: In lieu of the ▲ key, pressing the **F** key will advance the indicator to the next parameter.

2. FULL SCALE TRANSDUCER CALIBRATION

The display alternates between **FU.S.C.** and the value of full scale in engineering units.

Press the **▲** key once.

The display shows **FU on**.

Press **F** to go to perform the full scale calibration.

The indicator automatically returns to operating mode after 6 seconds if no changes are made.

3. TARE CALIBRATION (weight applications only)

The display alternates shows **tArE** and the value of the tare in engineering units. The tare will be forced to zero whenever zero or full scale calibration is performed. At this point there are two options:

- a. To perform calibration press **▲**.

The display shows **tA**, followed by:

OFF to disable calibration

ON to enable calibration

- b. If calibration is not needed, press **F** to go to the next parameter. The instrument automatically returns to operating mode after 6 seconds if no changes are made.

5.3 ALARM SET POINTS

If the indicator has automatically returned to operating mode you can return to set the alarms by following the procedure.

1. Alarm 1

Press **F** four times. The display will alternately show **1.xxxx** and the alarm set point where **xxxx** is a code for alarm operation mode. Only the alarm set point is shown during modification. Use the **▲** and **▼** keys to modify this parameter. Resolution and decimal point position are as selected for the readout value. Press **F** to store your change. The indicator automatically returns to the normal operating mode after 6 seconds if no changes are made.

The codes for the remaining digits in the alarm operating mode are:

2nd digit	3rd digit	4th digit	5th digit
H = High alarm	A = Automatic reset	d = Direct action	n = Low alarm mask
L = Low alarm	n = Manual reset	r = Reverse action	blank = Not masked

for example, a display of **1.HAr** would indicate High alarm, auto reset, reverse action.

2. Alarm 2

The indicator will automatically enter this parameter after the **F** key is pressed to store the Alarm 1 set point. To enter Alarm 2 from the normal operating mode, press **F** five times. Programming the Alarm 2 set point is the same as Alarm 1 above, except that the display alternately shows **2xxxx** and the alarm value.

5.4 ALARM RESET FUNCTION

This function can be performed when the indicator is locked; must be in local mode. If the alarm is configured as a latched alarm (manual reset), alarm status is maintained even after the alarm condition stops.

Press **R** + either arrow (**▲** or **▼**) to reset both Alarm 1 and Alarm 2. The external contact, if enabled, resets both alarms. The rear terminal connections are 7 and 8. The external contact works even if the indicator is in remote mode.

5.5 PEAK HOLD FUNCTION

The following actions can be performed when the indicator is locked, and in either local or remote mode.

- a. Monitoring Peak High and Peak Low.
By pressing **▲** while the measured value is displayed, it is possible to monitor the peak high value. The decimal point at the right of the display will be lit steadily.
Press **▲** again to monitor the peak low value. The decimal point at the right of the display will now blink on and off.
Press **▲** to redisplay the measured value (normal operating mode).
Press **R + F** to reset the peak high/peak low values and to restart for a new peak detection.
- b. Hold-on value
The external contact can be used to freeze input signal sampling, holding the last measured value for use on the display, alarms, retransmission, etc.
In this mode, the numerical value flashes on the display.

6. DEFAULT DATA LOADING PROCEDURE

In each one of the indicator's three modes, configuration, calibration, and operation, you can load default data to reset all of the parameters for that particular mode.

To load the default data:

Press **▼ + ▲**, and once the display shows **dF OFF**, press **▲**. When the display shows **dF On** press **F**. Default data will now be loaded. During data loading time the display will show **L.dAtA**.

The default data for the three modes are shown on the following pages.

6.1 DEFAULT DATA FOR CONFIGURATION PARAMETERS

Parameter	Description	Setting
A	Line frequency	60 Hz
B	Decimal point position	None
B1	Full scale readout	10000
C	Display filter time constant	400 ms
D	Input Interrupt	High
E	Shunt calibration	Enable
E1	Shunt calibration value	80.0%
F	External contact function	Alarm manual reset
F1	Contact status	Closure
G	Alarm 1 operating mode	High with automatic reset
G1	Alarm 1 action	Reverse
G2	Alarm 1 masking option	Disable
G3	Alarm 1 filter	Off
G4	Alarm 1 hysteresis	1.0%
H	Alarm 2 operating mode	High with automatic reset
H1	Alarm 2 action	Reverse
H2	Alarm 2 masking option	Disable
H3	Alarm 2 filter	Off
H4	Alarm 2 hysteresis	1.0%
I	Serial communication type	OFF (w/o RS485) ERO (w/ RS485)
I1	Serial communication address	1
I2	Serial communication Baud rate	19200
I3	Serial communication byte format	7 bit, parity even
L	Analog retransmission type	0.00 (Disable)
L1	Analog retrans. low scale value	0.00
L2	Analog retrans. full scale value	10000
L3	Analog retransmission filter	Off

6.2 DEFAULT DATA FOR OPERATING PARAMETERS

Parameter	Description	Setting
1	Zero transducer calibration	0 mV
2	Full scale transducer calibration	33.3 mV
3	Tare calibration	0 mV
4	Alarm 1 threshold setting	40% of fsv
5	Alarm 2 threshold setting	60% of fsv
6	Keyboard status	Unlocked

6.3 DEFAULT DATA FOR CALIBRATION PARAMETERS

Default calibration parameters are provided to allow the user to verify that the instrument is working properly. They are not normally used as the final calibration values.

CAUTION: After default parameter loading, you should perform the proper indicator calibration procedure.

7. ERROR MESSAGES

Diagnostics are performed at instrument startup and during normal mode operation. If a fault condition is detected, the display will show the message **Er** followed by an error code. The following is a list of possible errors in numerical order.

Er 1

The alarm threshold values or transducer calibration (tare or zero) are out of limits or their values in memory are incorrect. The error may appear at instrument startup in operating mode.

After 3 seconds, the instrument will reset. Simultaneously press ▼ and ▲ to load default data. Then load the desired threshold values and recalibrate the transducer.

Er 6

This error message appears during tare or zero transducer calibration if input value is greater than $\pm 25\%$ of full scale calibration. The same error message appears during full scale calibration if the stored zero calibration value is greater than $\pm 25\%$ of the new full scale calibration. In both cases the stored calibration value is not changed. This error message disappears automatically after 2 seconds.

Er 7

This error message appears during zero or full scale transducer calibration if a fault condition (hold-on-value/overrange/underrange/input open) is found on an input signal or if the span value is too large (>55 mV) or too small (<2.8 mV). In both cases the stored calibration value is not changed. This error message disappears automatically after 2 seconds.

Er 38

Error detected during EARAM read operation. This error may appear at instrument startup in operating mode. This error message disappears automatically after 3 seconds, and the instrument resets. If the error persists, return the instrument to your supplier.

If this error appears during configuration/calibration, press **F** or **R** to restart the procedure and then repeat operations. If the error persists, return the instrument to your supplier.

Er 39

Error detected during EAROM write operation. This error may appear in operating mode when storing a new value in EAROM (for example, alarm threshold or transducer calibration). The new values will be enabled but they will be lost when the instrument is powered down. This error message disappears automatically after 10 seconds.

If this error appears during configuration/calibration, press **F** or **R** to restart the procedure and then repeat operations. If the error persists, return the instrument to your supplier.

Er 101

The configuration data stored in EAROM is wrong or inconsistent. The error may appear at instrument startup in operating mode. This error message disappears automatically after 3 seconds, and the instrument resets.

If the error persists, enable configuration/calibration mode with the internal switch, load the default calibration data and then perform a new configuration.

Er 201

The calibration data stored in EAROM for analog retransmission is wrong. The error may appear at instrument startup in operating mode. This error message disappears automatically after 3 seconds, and the instrument resets.

If the error persists, enable configuration/calibration mode with the internal switch, load the default calibration data and then perform a new analog retransmission calibration.

Er 312

Error during internal autozero measurement for temperature drift compensation. The instrument repeats this check every 3 seconds. The analog retransmission and alarm go low scale or high scale as a failsafe configuration. If the error persists, return the instrument to your supplier.

Er 402

The configuration/calibration data stored in EAROM is not protected. The error may appear at instrument startup in operating mode. This error message disappears automatically after 3 seconds, and the instrument resets.

If the error persists, enable configuration/calibration mode with the internal switch, power up the unit and then return to operating mode. This action should be sufficient to enable data protection.

o o o o o

Over-range indication

This status is displayed when the A/D converter value is out of range, or the input signal is greater than full scale value plus 27% of span, or the displayed value exceeds the display capability of 99900.

- 0 0 0 0

Under-range indication

This status is displayed when the A/D converter value is out of range, or the input signal is lower than low scale value minus 27% of span, or the displayed value exceeds the display capability of -1990.

OPEn

This message is displayed when the instrument detects an input on any one of the four transducer leads.

8. REPAIR

Questions concerning warranty, repair cost, delivery, and requests for a RA# should be directed to the Dynisco Repair Department, 508-541-9400 or email: repair@dynisco.com. Please call for a return authorization number (RA#) before returning any product. Damaged products should be returned to:

DYNISCO LLC

Attn: RA # _____

38 Forge Parkway

Franklin, MA 02038

For technical assistance please call 800-DYNISCO or 508-541-9400 or fax 508-541-9436.

9. WARRANTY

This Dynisco product is warranted under terms and conditions set forth in the Dynisco Web Pages. Go to www.dynisco.com and click on "Warranty" at the bottom of any page for complete details.

NOTES:

WARRANTY REGISTRATION CARD



MODEL NUMBER _____

SERIAL NUMBER _____

DATE PURCHASED _____

PURCHASED FROM _____

NAME _____

COMPANY _____

DIVISION _____

STREET _____

CITY _____ STATE _____ ZIP _____

COUNTRY _____

TELEPHONE _____ FAX _____

My application is _____

Is this your first purchase from Dynisco? YES _____ NO _____

How did you first hear of Dynisco? ADVERTISING _____ REP _____

PREVIOUS USE _____ COLLEAGUE _____ DIRECTORY _____

I need further product information on _____

I need application help on _____

Please send complete catalog _____

Tel.: 508-541-9400 Fax: 508-541-9436 E-mail: www.dynisco.com

PLEASE FOLD AND STAPLE OR TAPE



Place
Stamp
Here

DYNISCO LLC
38 FORGE PARKWAY
FRANKLIN, MA 02038

ATTN: MARKETING DEPT.

DyniscoLLC
38 Forge Parkway
Franklin, MA 02038
USA

Tel: +1 508 541 9400
Fax: +1 508 541 9436
Email: Infolnst@dynisco.com

Dynisco Extrusion
1291 19th St Ln NW
Hickory, NC 28601

Tel: 828-326-9888
Fax: 828-326-8882
Email: InfoExtr@dynisco.com

Dynisco Polymer Test
Westgate II
730 Hemlock Road
Morgantown, PA 19543

Sales & Service:
Tel: 508-541-9400
Fax: 508-541-6206
Email: InfoPT@dynisco.com

Dynisco Europe GmbH
Wannenäckerstraße 24
74078 Heilbronn
Deutschland

Tel: +49 7131 2970
Fax: +49 7131 23260
Email: DyniscoEurope@dynisco.com

Dynisco Instruments S.a.r.l.
466, rue du Marché Rollay
94500 Champigny sur Marne
France

Tel: +33 1 4881 8459
Fax: +33 1 4881 8334
Email: DyniscoFrance@dynisco.com

Dynisco.s.r.l.
Via Adriatico, 2/2
20162 Milano
Italia

Tel: +39 02 661 01733
Fax: +39 02 661 02908
Email: Dyniscoltaly@dynisco.com

Dynisco UK Ltd.
Silver Birches Business Park
Aston Road, Bromsgrove
Worcestershire B60 3EU
Great Britain

Tel: +44 1527 577077
Fax: +44 1527 577070
Email: DyniscoUK@dynisco.com

Dynisco SPOL, S.R.O.
cp. 579
756 55 Dolni Becva
Czech Republic

Tel: +42 0651 647228
Fax: +42 0651 647224
Email: Dynisco_cz@ova.pvtnet.cz

Dynisco B.V.
Muziekplein 67
PO Box 666
NL-5400 AR Uden
The Netherlands

Tel: +31 413 250665
Fax: +31 413 260548
Email: Dynisco-BV@dynisco.com

Dynisco Spain
Edificio la Constructora
C/Vallespir 24, Local No. 4
08970 Sant Joan Despi/ Barcelona
España

Tel: +34 934 77 65 20
Fax: +34 933 73 72 60
Email: DyniscoSpain@dynisco.com



Dynisco
Service

24 HOURS A DAY
7 DAYS A WEEK

www.dynisco.com

1-800-DYNISCO (US)
00-800-DYNISCO-0 (Europe)